

SIZE	DN	L	ØD	n-UNC	∠°
2"	50	4.2	120.7	4-UNC 5/8"	90°
2 1/2"	65	4.7	139.7	4-UNC 5/8"	90°
3"	80	4.5.2	152.4	4-UNC 5/8"	90°
4"	100	5.2.1	190.5	8-UNC 5/8"	45°
5"	125	5.4.4	215.9	8-UNC 3/4"	45°
6"	150	5.5.8	241.3	8-UNC 3/4"	45°

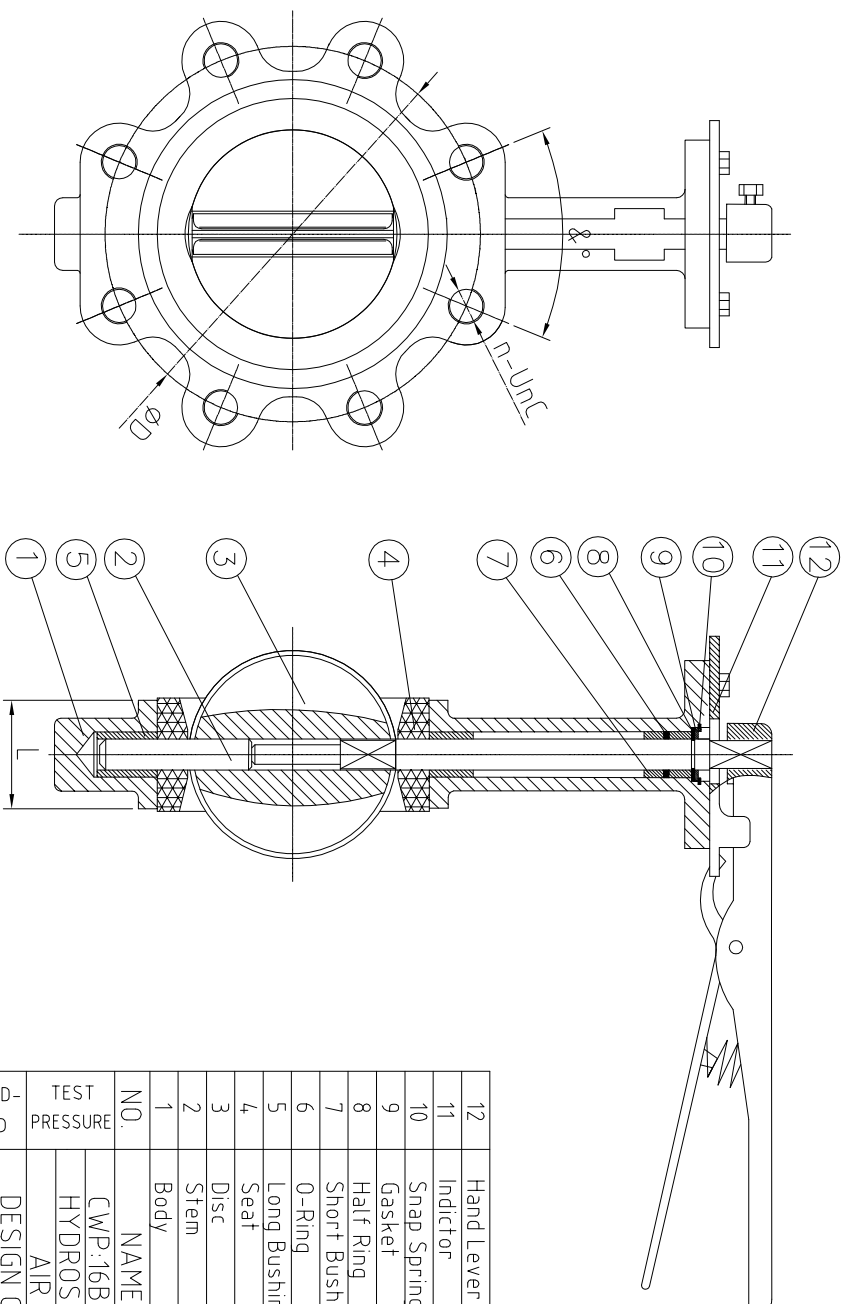

NO.	NAME	MATERIAL	QTY
12	Hand Lever	ASSEMBLY	1
11	Indicator	SS	1
10	Snap Spring	SK7	1
9	Gasket	13Cr	1
8	Half Ring	13Cr	1
7	Short Bushing	PTFE	2
6	O-Ring	NBR	1
5	Long Bushing	PTFE	2
4	Seat	NBR	1
3	Disc	A351 CF8M (SS316)	1
2	Stem	A276 SS4.16	1
1	Body	Ductile Iron ASTM A536 + Epoxy	1

TEST PRESSURE	SHELL	SEAL
CWP:16Bar	24 bar	17.6 bar
HYDROSTATIC	6 bar	6 bar
AIR		

DESIGN CODE	API 609
INSPECTION & TEST	API 598
END STANDARD	ASME B16.5 150LB
FACE TO FACE	API609

TITLE: HANDLEVER CONCENTRIC BUTTERFLY VALVE
NPS 2"-~6" - 150LB - LUG

1	Nondestructive Testing		
1.1	Pressure Test	API 598	Yes
1.2	Chemical composition certification	Mandatory	Yes
1.3	Penetrant Test	All Body Surface	Yes
1.4	Magnetic particle testing	All Body Surface	Yes

APPROVED		DWG NO:	REV
CHECKED			
DRAWN			
DESIGNED		SCALE	UNIT mm